

SunPower® Complete Confidence

A better warranty starts with a better product.



25 years

- Panels
- Microinverters
- Racking
- Power production

10 years

- Monitoring hardware



*Smartphone and laptop not included.

Every part of your SunPower Equinox™ system is meticulously designed to work perfectly together, and rigorously tested for long-term reliability. That's why the **SunPower® Complete Confidence Warranty** is the only warranty to cover your whole system (not just the panels).

Complete System

SunPower stands behind your entire system—including power production. That way you never have to wonder which company you can depend on.

One company

- The only company that stands behind your entire system.

Easy process

- No need for receipts, proof of purchase or written claims.

Most comprehensive coverage

- 25 years—system on your roof.
- 10 years—monitoring technology.

Highest 25-year production warranty

- At a record-breaking 0.25% degradation rate, your SunPower® system will continue to produce more energy than any other system on the market.

Complete Service

If you experience issues with your system within 25 years of purchase, SunPower will happily replace, fix, or reimburse you—hassle free.

Easy to reach

- Our national network means a SunPower-certified installer is right in your neighborhood. And as a US-based company, we're always just a call away at 1-800-SUNPOWER.

Provides 100% of repair or replacement costs

- Labor, shipping, parts—we take care of everything.

Conventional System

Each part is made and warranted by a different manufacturer.

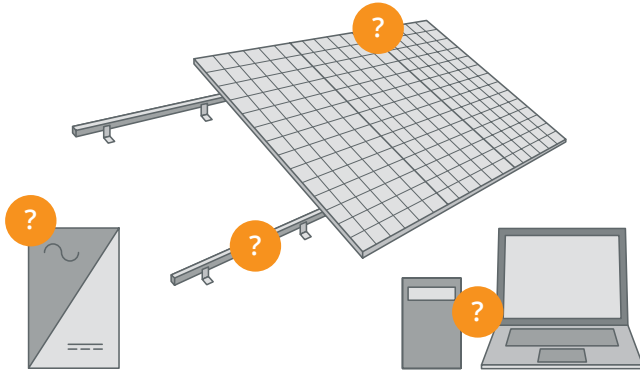

SunPower System

One company backs everything.

*Smartphone and laptop not included.



Pitfalls of conventional solar warranties:

- You pay to ship new panels
- You pay to package and ship defective panels
- You must present original physical proof of purchase
- You must make claims in writing
- You have a short time frame to make a claim
- You pay the manufacturer a testing fee if they don't find a defect

	SunPower® Complete Confidence	Conventional Solar Warranties*	LG Solar Warranty	Panasonic Solar Warranty
Product Quality				
Panel	25 Years	10 Years	12 Years, 25 Years†	12 Years, 25 Years††
Inverter	25 Years	N/A (separate inverter manufacturer warranty)	N/A (separate inverter manufacturer warranty)	N/A (separate inverter manufacturer warranty)
Racking	25 Years	N/A (separate racking manufacturer warranty)	N/A (separate racking manufacturer warranty)	N/A (separate racking manufacturer warranty)
Monitoring Technology	10 Years	N/A (separate monitoring manufacturer warranty)	N/A (separate monitoring manufacturer warranty)	N/A (separate monitoring manufacturer warranty)
Power Warranty (covers steady decline in performance)				
Start point	98%	97.5%	98%, 95%	97%
Yearly decline	0.25%	0.7%	0.55%, 0.4%	0.26%
End point	92%	80.7%	84.8%, 87%	90.8%
Included Servicing / Labor				
Shipping – new part	Yes	No**	Panel Only	No
Shipping – old part	Yes	No	No	No
Installation	Yes	No	No	No
Warranty Terms to Note				
	Excludes direct contact with bodies of salt water (beachside acceptable)	* Representative of standard-efficiency solar manufacturers such as Trina, YingLi and Canadian Solar. Competitor warranty information provided from latest warranty documents, as of 2017. ** Shipping covered by some conventional warranties.	† 25 years only on LG Neon R panels. • Excludes salt and rust damage • Excludes transport and packaging • Customer pays if no fault is found by LG • Original sales receipt required	†† 25 years only if system registered within 90 days and installed by select authorized Panasonic dealers. • Excludes rust damage, transport damage, and damage by “external stress and strain” • Panels must remain on the original roof • Subtract 5% of power in favor of Panasonic • Claims require original paper guarantee and invoice

1 Conventional manufacturer warranty information verified by latest warranty documents online of various manufacturers, as of June 2017.