



SUNNY TRIPOWER 60-US

STP60-US-10



Efficient

- Maximum efficiency of 98.8%
- Superior power density: 60 kVA at only 165 pounds

Reliable

- Distributed architecture for maximum system availability
- Central control with SMA Inverter Manager

Cost-Effective

- DC input of up to 1,000 V
- Up to 2.5 MW per inverter manager

Innovative

- Suitable for commercial and utility applications
- Complete grid management feature set

SUNNY TRIPOWER 60-US

The efficient solution for medium to large-scale PV Plants

The new Sunny Tripower 60-US is part of an innovative, global system solution for commercial and utility PV plants. This solution combines the advantages of a decentralized system layout with the benefits of centralized inverter designs which results in the best of both worlds. High efficiency, easy installation, simple commissioning and low maintenance requirements contribute decisively to reducing the operating costs for the entire plant.

THE SMART SUNNY TRIPOWER 60-US SYSTEM PHILOSOPHY

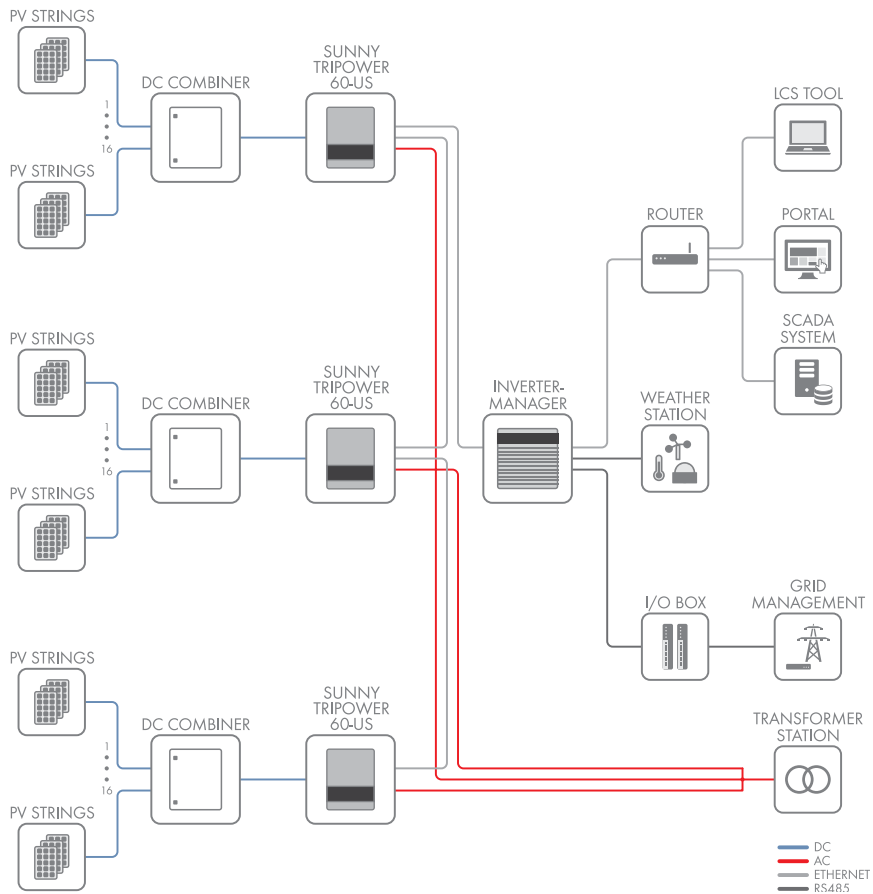



UNMATCHED POWER DENSITY

With Maximum Efficiency

The new SMA system solution consists of three components: highly efficient Sunny Tripower 60-US inverters, the SMA Inverter Manager and the LCS commissioning tool. It is precisely this systemized approach that makes the Sunny Tripower 60-US so unique and ensures a high level of performance.

System Cost Reduction

With a compact design of 60 kVA weighing only 165 pounds, the Sunny Tripower 60-US requires little space, reduces on-site preparation work, simplifies installation and lowers maintenance costs.

Innovative system management

The SMA Inverter Manager is the central communications component and sole interface for the entire system control. It handles all the important inverter and system management functions for up to 2.5 MW with a single inverter manager.

The Sunny Tripower 60-US benefits from a self-configuring inverter network with automatic IP configuration and device discovery, which eliminates manual setup. The SMA Inverter Manager also creates a seamless inverter control loop which enables complete grid management capabilities.

Simple commissioning

The specially developed LCS tool (Local Commissioning and Service Tool) makes commissioning easy, saves time and reduces costs. The inverter is configured by simply selecting the system-specific configuration files and then transmitting them to all inverters. In addition, individual inverter data is aggregated into a single plant profile for comprehensive plant performance analysis.

Technical data	Sunny Tripower 60-US
Input (DC)	
Max. input voltage	1,000 V
MPP voltage range	570 V to 800 V @400 VAC, 685 V to 800 V @480 VAC
Min. input voltage	565 V @400 VAC, 680 V @480 VAC
Max. input current / short-circuit current	110 A / 150 A
Number of independent MPP inputs / strings per MPP input	1/1 (split up by external PV array junction box)
Output (AC)	
Rated power at nominal voltage	60,000 W
Max. apparent AC power	60,000 VA
Output Phases / line connections	3 / PE
Nominal AC voltage	400 V, 480 V
Nominal AC voltage range	352 V to 440 V @400 VAC, 423 V to 528 V @480 VAC
AC power frequency	50 Hz, 60 Hz
Rated power frequency / rated grid voltage	50 Hz, 60 Hz / 400 V, 480 V
Max. output current	3 x 87 A @ 400 V, 3 x 72 A @ 480 V
Power factor at rated power/displacement power factor adjustable	1/0.8 lagging ... 0.8 leading
Feed-in phases / connection phases	3 / 3
Efficiency	
Max. efficiency / CEC @ 400 VAC / CEC @ 480 VAC	98.8% / 98.0% / 98.5%
Protective devices	
DC-side disconnection point / DC surge arrester (type II) can be integrated	● / ●
Ground fault monitoring / grid monitoring	● / ●
DC reverse polarity protection / AC short-circuit current capability / galvanically isolated	● / ● / -
All-pole sensitive residual-current monitoring unit	●
Protection class (acc. to IEC 62103)/overvoltage category (acc. to IEC 60664-1)	I / AC: III, DC: II
General data	
Dimensions (W / H / D) / weight	570 / 740 / 300 mm (22.4 / 29.1 / 11.8 inch) / 75 kg (165.3 lbs)
Operating temperature range	-25 °C ... +60 °C (-13 °F to +140 °F)
Noise emission, typical / Self-consumption (at night)	55 dB(A) / 3W
Topology / cooling concept, degree of protect. (IEC 60529/UL50E), climatic cat. (IEC 60721-3-4)	Transformerless / active, IP65 / NEMA 3R, 4K4H
Maximum permissible value for relative humidity (non-condensing)	95%
Features	
DC connection / AC connection	Screw terminal / screw terminal
Display / Interface	Graphic / Using external inverter manager: Modbus TCP
● Standard features ○ Optional features - Not available	

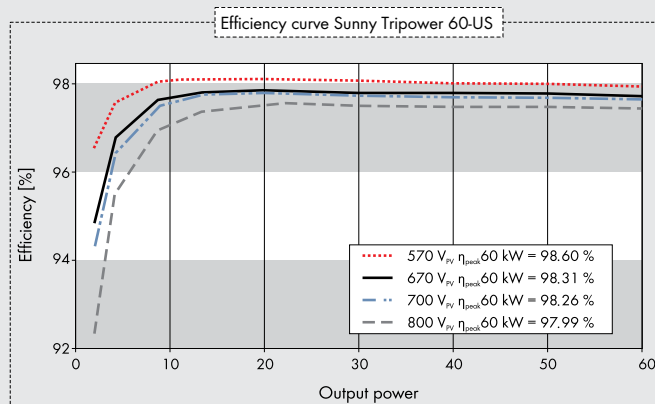

Type Designation

Sunny Tripower 60-US:
STP 60-US-10 with DC Switch

SMA Inverter Manager:
IM-10: SMA Inverter Manager for max. 42 inverters

I/O Module:
IM-DIO-10: SMA Digital I/O Box with 6 digital inputs

Certificates and Approvals

Sunny Tripower 60-US: IEC 62109-1/IEC 62109-2 (Class I, grounded-communication Class II, PELV), UL1741-w. Non-Isolated EPS Interactive PV Inverters, IEEE 1547, FCC Part 15, Subpart B Class A

SMA Inverter Manager: UL 508, UL 60950-1, CSA C22.2 No. 60950-1-07, EN 60950-1, EN 55022 Class A, EN 61000-3-2 Class D, EN 61000-3-3, EN55024, FCC Part 15, Subpart B Class A

Technical data	SMA Inverter Manager
Voltage supply	
Input voltage	9 - 36 Vdc
Power consumption	< 20 W
General data	
Dimensions (W / H / D) / weight	160 / 125 / 49 mm (6.3 / 4.9 / 1.9 inch) / 940 g (2 lbs)
Degree of protection / assembly	IP21 / DIN top-hat rails or wall mounting
Operating temperature range / relative humidity	-40 to +85 °C / 5 - 95 % (non-condensing)
Cooling concept	Convection
Interfaces	
User interface / Sensor interface	LCS tool for PC / RS-485 for SunSpec Alliance compatible weather stations
Active and reactive power setpoints	Constant values, curves, remotely controlled
Interface to inverter network / Interface to external network	1 Ethernet port (RJ45) / 1 Ethernet port (RJ45) Modbus TCP, SunSpec Alliance
Interface to remote control	6 x DI, Modbus TCP via external I/O module
Data at nominal conditions	